

NOTE: 1  
DESIGN CODE:  
N/A

NOTE: 2  
TECHNICAL CLASSIFICATION:  
Article Type: 003-Valve Stabs  
Main Group: 3.04. Ø60-Valvestab  
Intermediate Group: 3.34.01. Stab  
Sub Group: 3.34.74.2. Dual

NOTE: 3  
INTERFACE INFORMATION:  
Pressure Rating Bar: 0  
Material: PEHD 1000  
Weight: 0,2 kg  
Volume: 0,24 dm<sup>3</sup>  
Surface Area: 670 cm<sup>2</sup>  
Hydraulic: N/A  
Mechanical: N/A  
Electrical: N/A  
Com. & Protocol: N/A

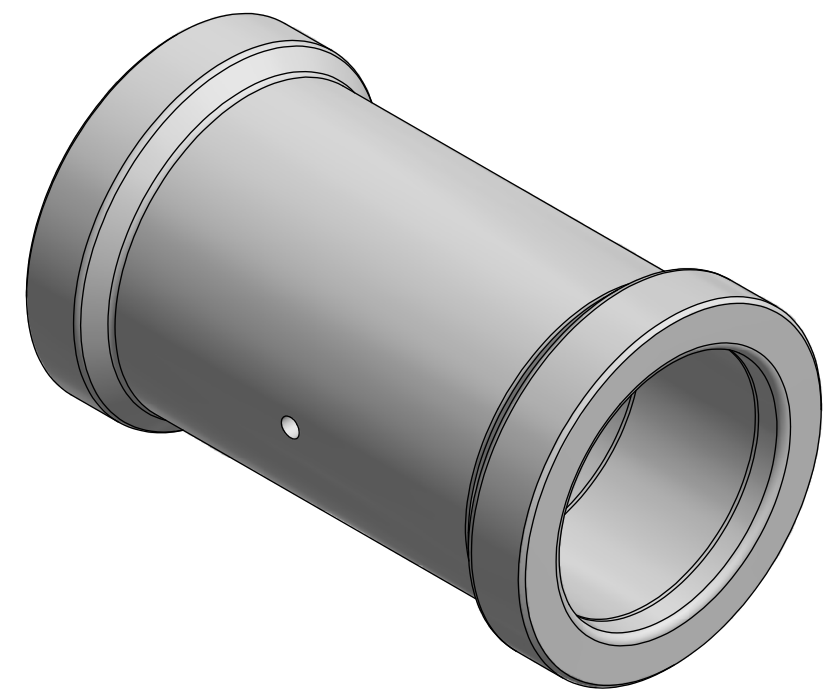

Rev.	Date	Reason for issue	Revision change	Made	Chk'd	Appr.
01	19.9.2024	7-IFC (Issued for Construction)		HNJ	LGH	HNJ



Unless Noted Otherwise:	Dwg Scale: NTS
Dim. Tol: NS-ISO 2768-1	Dwg Proj:
Roughness: Ra	Dwg Format: A3
Fillet Rad: Corner Rmax:	Break Edges: (R. Alt. 45°) R= 0,1-0,5

Drawing title: Ø60 Valve Stab DP Protection Sleeve	Rev: 01
Drawing number: BC1690	