

Parts List			
ITEM	QTY	PART No.	DESCRIPTION
1	1	BA8372	Ø55/Ø57 HP VStab with Metallic Key
2	1	BA8367	Ø55/Ø57 HP VStab Rec BSP 3/8" wLock Mechanism Metallic Key

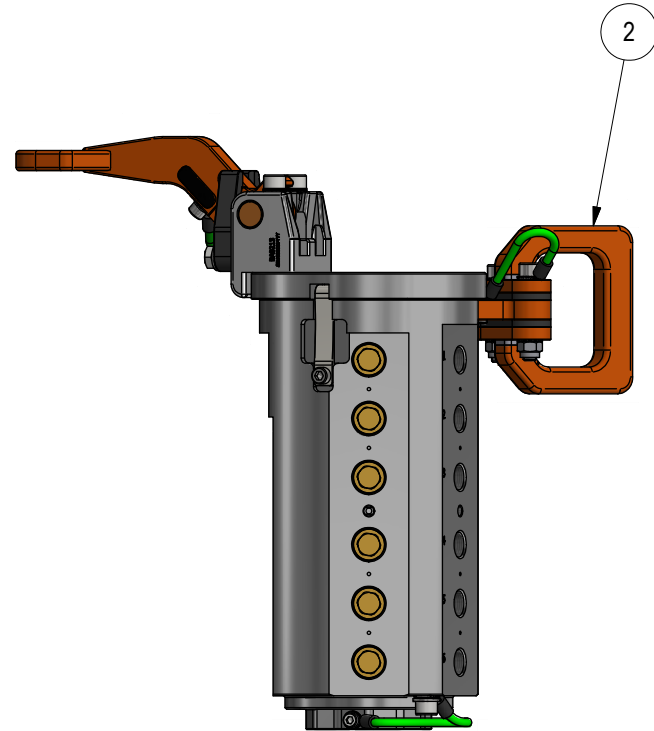

NOTE: 1
 ADDITIONAL INFORMATION:
 This overview drawing shows the basic version of Ø55/Ø57 Valve Stab and Valve Stab Receptacle. Pressure rating 690bar and maximum flow capacity approx. 45 l/min. Pressure Stabs and Protection/Parking Stabs and Receptacles are also available.

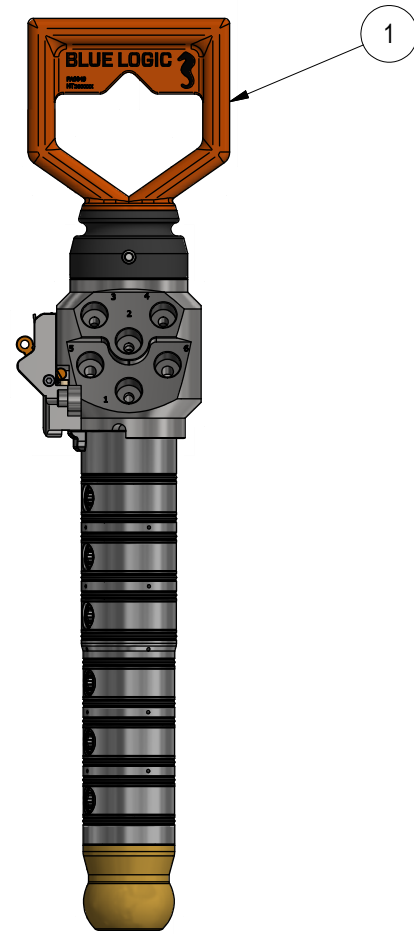
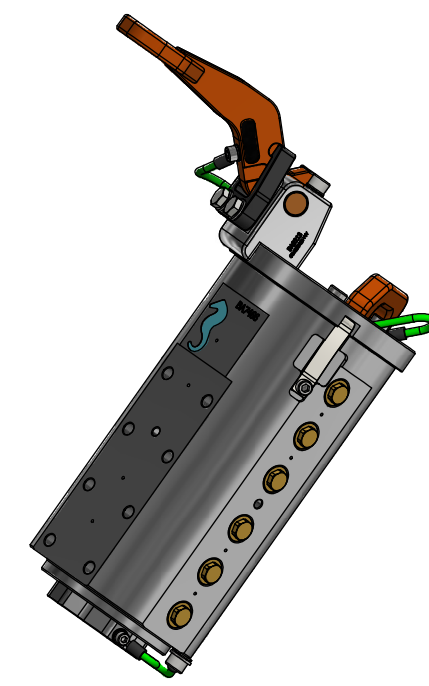

FOR INFORMATION ONLY

Rev.	Date	Reason for issue	Revision change	Made	Chk'd	Appr.
01	8.2.2024	2-IFT (Issued for Tender)		HNJ		

BLUE LOGIC 

This Drawing is the Property of Blue Logic AS © and must Not be Loaned, Reproduced or Transferred to others without written Permission

Dwg Scale:	NTS
Dwg Proj:	
Dwg Format:	A3

Drawing title:	Ø55/Ø57 Valve Stab System Overview	
Drawing number:	BC0795	Rev. 01