

NOTE: 1  
 DESIGN CODE:  
 N/A

NOTE: 2  
 TECHNICAL CLASSIFICATION:  
 Article Type: 003-Valve Stabs  
 Main Group: 3.07. Ø55/Ø57-Valvestab  
 Intermediate Group: 3.42.01. Stab  
 Sub Group: 3.42.102.6. Hexa

NOTE: 3  
 INTERFACE INFORMATION:  
 Pressure Rating Bar: 0  
 Material: PEHD 1000  
 Weight: 0,4 kg  
 Volume: 0,43 dm<sup>3</sup>  
 Surface Area: 1066 cm<sup>2</sup>  
 Hydraulic: N/A  
 Mechanical: N/A  
 Electrical: N/A  
 Com. & Protocol: N/A

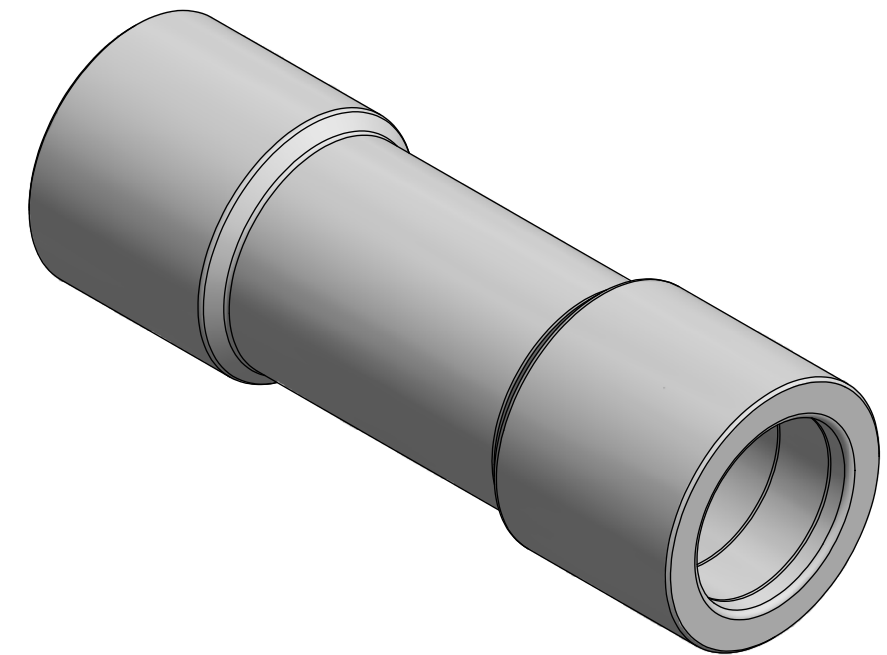
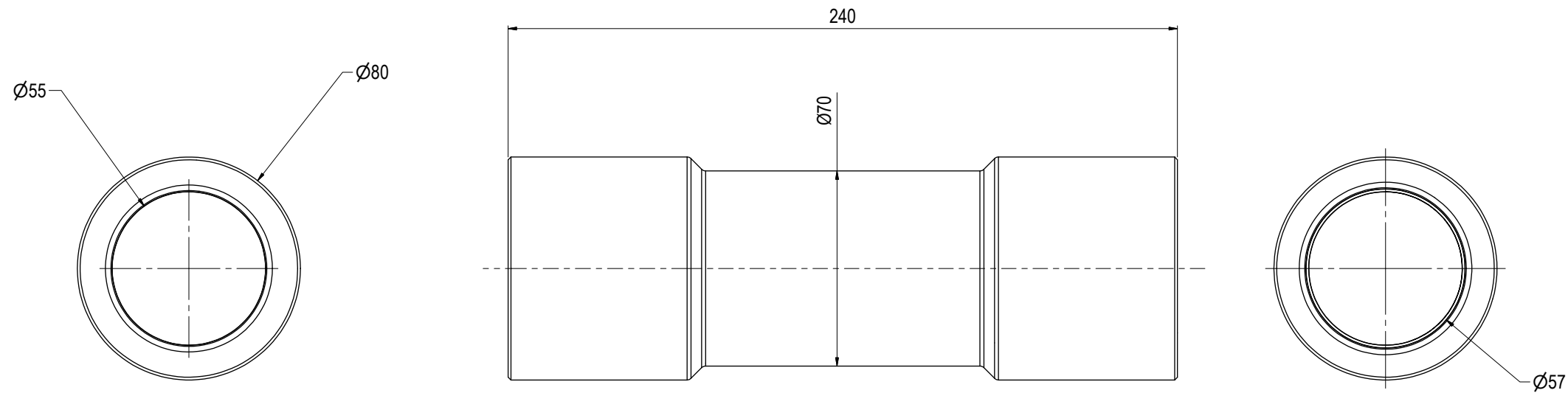

Rev.	Date	Reason for issue	Revision change	Made	Chk'd	Appr.
02	7.10.2020	7-IFC (Issued for Construction)		HNJ	LGH	HNJ
01	14.12.2018	7-IFC (Issued for Construction)		WTJ	LAE	WTJ



Unless Noted Otherwise:  
 Dim. Tol: NS-ISO 2768-1  
 Roughness: Ra  
 Fillet Rad:  
 Corner Rmax:

Dwg. Scale: NTS  
 Dwg. Proj:   
 Dwg. Format: A3  
 Break Edges: (R. Alt. 45°) R= 0,1-0,5

Drawing title: Ø55/Ø57 Valve Stab HP Protection Sleeve  
 Drawing number: BA8922  
 Rev: 02