

NOTE: 1
DESIGN CODE:

NOTE: 2
TECHNICAL CLASSIFICATION:
Article Type: 003-Valve Stabs
Main Group: 3.03. Ø55-Valvestab
Intermediate Group: 3.12.02. Receptacle
Sub Group: 3.12.69.6. Hexa

NOTE: 3
INTERFACE INFORMATION:
Pressure Rating Bar: 0
Material: PEHD 1000
Weight: 0,4 kg
Volume: 0,46 dm³
Surface Area: 1057 cm²
Hydraulic: N/A
Mechanical: N/A
Electrical: N/A
Com. & Protocol: N/A

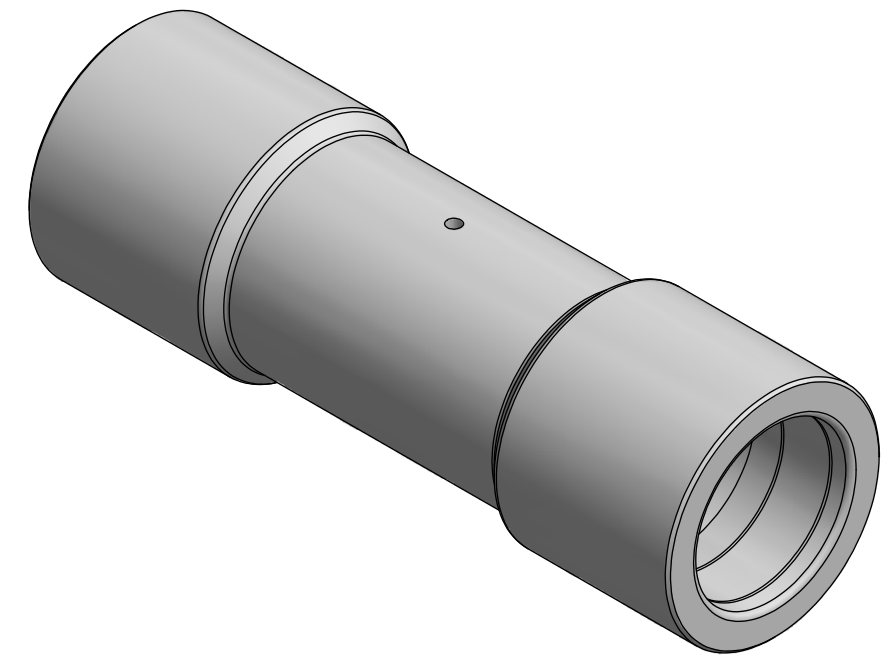
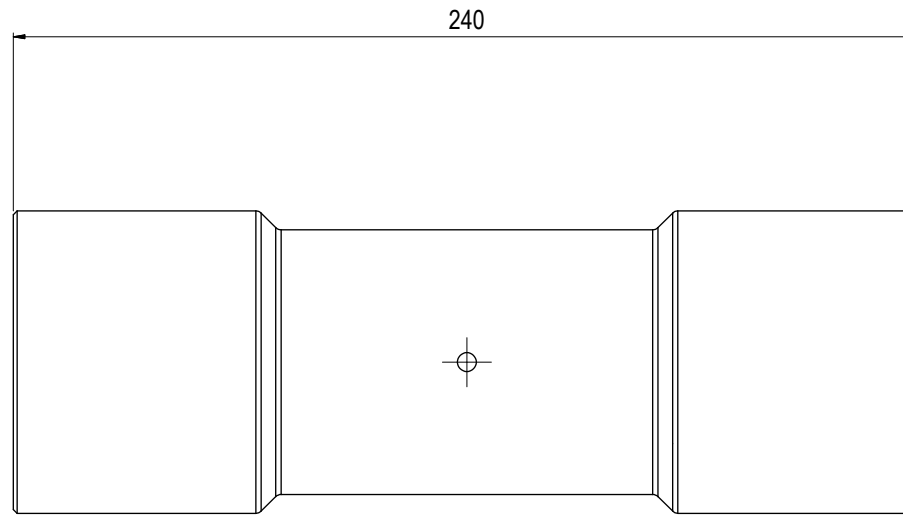
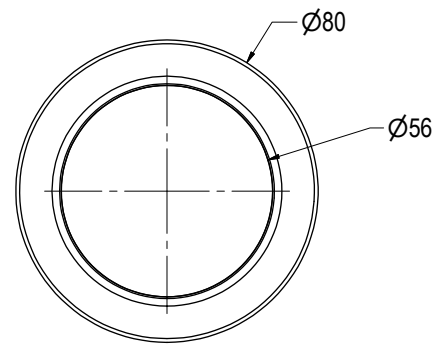

Rev.	Date	Reason for issue	Revision change	Made	Chk'd	Appr.
03	19.9.2024	7-IFC (Issued for Construction)		HNJ	LGH	HNJ
02	12.4.2022	7-IFC (Issued for Construction)		HNJ	TAN	HNJ
01	24.4.2013	7-IFC (Issued for Construction)		LAE	LGH	LAE



Unless Noted Otherwise:	Dwg Scale: NTS
Dim. Tol: NS-ISO 2768-1	Dwg Proj:
Roughness: Ra	Dwg Format: A3
Fillet Rad: Corner Rmax:	Break Edges: (R. Alt. 45°) R= 0,1-0,5

Drawing title: Ø55 Valve Stab HP protection Sleeve	Rev: 03
Drawing number: BA3539	